

## Installation and Operating Instructions for Complete Freewheels FGR, FGR A1A2, FGR A2A7, FGR A2A3, FGR A3A4

E 08.710 e



Any questions? Please contact us.

### Morskate Aandrijvingen BV

Oosterveldsingel 47A  
7558 PJ Hengelo (Ov)  
The Netherlands

NL  
T +31 (0)74 - 760 11 11  
info@morskateaandrijvingen.nl  
www.morskateaandrijvingen.nl

DE  
T +49 692 - 222 34 95  
info@morskateantriebstechnik.de  
www.morskateantriebstechnik.de

EN  
T +31 (0)74 - 760 11 11  
info@morskatedrivetechnology.com  
www.morskatedrivetechnology.com

<b>RINGSPANN</b>	<b>Installation and Operating Instructions for Complete Freewheels FGR, FGR A1A2, FGR A2A7, FGR A2A3, FGR A3A4</b>	<b>E 08.710 e</b>			
Stand: 23.12.2010	Version : 03	gez.: Su	gepr.: Ei	Seitenzahl: 10	Seite: 2

---

## Important

Please read these instructions carefully before installing and operating the product. Your particular attention is drawn to the notes on safety.

These installation and operating instructions are valid on condition that the product meets the selection criteria for its proper use. Selection and design of the product is not the subject of these installation and operating instructions.

Disregarding or misinterpreting these installation and operating instructions invalidates any product liability or warranty by RINGSPANN; the same applies if the product is taken apart or changed.

These installation and operating instructions should be kept in a safe place and should accompany the product if it is passed on to others – either on its own or as part of a machine – to make it accessible to the user.

---

## Safety Notice

- Installation and operation of this product should only be carried out by skilled personnel.
- Repairs may only be carried out by the manufacturer or accredited RINGSPANN agents.
- If a malfunction is indicated, the product or the machine into which it is installed, should be stopped immediately and either RINGSPANN or an accredited RINGSPANN agent should be informed.
- Switch off the power supply before commencing work on electrical components.
- Rotating machine elements must be protected by the purchaser to prevent accidental contact.
- Supplies abroad are subject to the safety laws prevailing in those countries.

<b>RINGSPANN</b>	<b>Installation and Operating Instructions for Complete Freewheels FGR, FGR A1A2, FGR A2A7, FGR A2A3, FGR A3A4</b>			<b>E 08.710 e</b>	
	Stand: 23.12.2010	Version : 03	gez.: Su	gepr.: Ei	Seitenzahl: 10

## 1. General information

Complete Freewheels of series FGR ... are power transmission components with particular characteristics:

- In one direction of rotation there is no contact between the inner and outer ring; the freewheel is in freewheeling operation.
- In the other direction of rotation there is contact between the inner and outer ring; in this direction it is possible to transmit high torque.

Complete Freewheels of series FGR ... are used as:

- Backstops
- Overrunning Clutches
- Indexing Freewheels



### **Attention!**

Freewheels can be used as safety construction units, therefore this installation and operating instructions must be obeyed carefully.

## 2. Applications of Freewheels

### 2.1 Application as Backstop

Freewheels are used as backstops if reverse rotation of the operating direction is to be prevented. In many machines and installations, for technical safety or functional reasons, it is necessary to ensure that you are working in just one specified direction of rotation. This is why there are legal stipulations requiring a mechanical safety device for the operation of, e.g. conveyor systems.

The normal operating mode of backstop is freewheeling operation; the locking (torque transmission) is performed at zero speed. The immediate engagement of the clamping elements ensures the required high operating safety.

### 2.2 Application as Overrunning Clutch

The overrunning clutch engages machines or machine parts and automatically interrupts their contact as soon as the driven part of the overrunning clutch is turned faster than the driving part. In many cases, this can replace a more expensive externally actuated clutch.

With overrunning chlutches the engagement takes place in the driving operation (torque transmission), while in freewheeling operation the torque transmission between the inner ring and outer ring is interrupted. In driving operation the speeds of the inner and outer ring are equal, while in freewheeling operation they are different.

<b>RINGSPANN</b>	<b>Installation and Operating Instructions for Complete Freewheels FGR, FGR A1A2, FGR A2A7, FGR A2A3, FGR A3A4</b>			<b>E 08.710 e</b>	
	Stand: 23.12.2010	Version : 03	gez.: Su	gepr.: Ei	Seitenzahl: 10

### 2.3 Application as Indexing Freewheel

The indexing freewheel transmits a back and forth motion into a stepped rotation (indexing feed). The RINGSPANN indexing freewheel works precisely and quietly and enables an infinitely adjustable setting of the feed.



#### Attention!

Reliable torque transmission between the freewheel is guaranteed only if the maximum permissible speed in driving operation of the freewheel is not exceeded.

**Operation at speeds in excess of the speeds permitted for the different operating modes can result in damage and overheating of the freewheel!**

### 3. Design

The Complete Freewheels of series FGR ... are made up of basic freewheel (Fig. [1] in the middle) and the corresponding attachments flange, cover, etc.

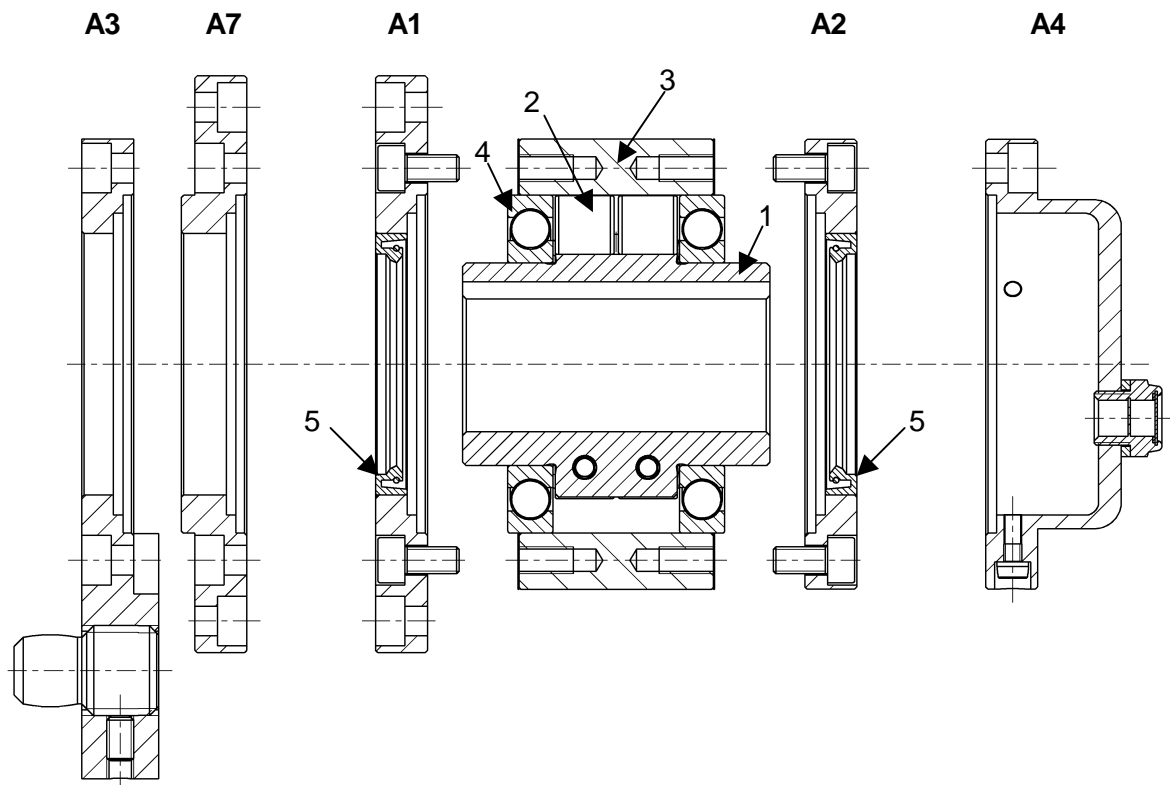

Fig. [1]

The essential functional components are the inner ring (1), the sprags (2), the outer ring (3), the bearings (4), the seals (5), the flange/cover combination A1A2 or A7A2, and the lever arm/cover combination A3A2 or A3A4 and the lubricant.

<b>RINGSPANN</b>	<b>Installation and Operating Instructions for Complete Freewheels FGR, FGR A1A2, FGR A2A7, FGR A2A3, FGR A3A4</b>			<b>E 08.710 e</b>	
	Stand: 23.12.2010	Version : 03	gez.: Su	gepr.: Ei	Seitenzahl: 10

#### 4. Types

The Complete Freewheels of series FGR ... are available in the following types:

- FGR – basic freewheel without attachments (Fig. [1] in the middle)
- FGR A1A2 – basic freewheel FGR with flange A1 and cover A2
- FGR A2A7 – basic freewheel FGR mit centering flange A7 and cover A2
- FGR A2A3 – basic freewheel FGR mit lever arm A3 and cover A2
- FGR A3A4 – basic freewheel FGR mit lever arm A3 and cover A4



#### **Please note!**

Further information especially on design, function and selection, permissible torques or permissible speeds of these freewheels is provided in RINGSPANN Catalog 84 "Freewheels". Please contact RINGSPANN GmbH if you need assistance.

#### 5. General instructions



#### **Attention!**

The maximum permissible freewheel torque must not be exceeded due to torque peaks in specific applications. To avoid possible torque peaks, which can damage the freewheel, which produce we recommend the use of torsionally stiff couplings, the low restoring forces.

The maximum freewheel torque should be calculated with the aid of RINGSPANN Catalog 84. Please consult with RINGSPANN if you need assistance.

**Freewheel damage resulting by excessive torque peaks impair component function and can result in excessive overheating of the freewheel!**



#### **Attention!**

If the machine or system is exposed to axial and/or radial loads, the roller bearings in the freewheel should be checked with reference to the rules for calculation provided by the bearing manufacturer. It is essential to ensure that bearings are not damaged.

**Bearing damage can result in overheating and the impairment of freewheel function!**

<b>RINGSPANN</b>	<b>Installation and Operating Instructions for Complete Freewheels FGR, FGR A1A2, FGR A2A7, FGR A2A3, FGR A3A4</b>			<b>E 08.710 e</b>	
	Stand: 23.12.2010	Version : 03	gez.: Su	gepr.: Ei	Seitenzahl: 10 Seite: 6



**Attention!**

Torsion vibrations (amplitudes and frequencies which result in engagement and release of the freewheel in rapid succession) must be avoided.

**Torsion vibrations can result in overheating and the impairment of freewheel function!**



**Attention!**

Seals must be correctly installed during the entire service life of the freewheel and must not be excessively worn.

Seals should be replaced as needed.

**Seal damage can result in overheating and the impairment of freewheel function!**

## 6. Condition at delivery

The Complete Freewheels of series FGR ... be either as complete freewheels supplied oil-filled and ready for installation or basic freewheel, flange, covers, seals and screws supplied delivered loose without oil. They are preserved with anti-rust oil, and are packed in anti-corrosion paper.

## 7. Technical requirements for safe operation

The bore in the inner ring normally has a tolerance of ISO H7. The tolerance of the shaft must be in this case ISO h6 or j6.

The feather key must have back play and may have only minimal width oversize, as otherwise the inner ring may be deformed.

## 8. Installation

The direction of machine or system rotation must be determined prior to freewheel installation.

Mark this direction with an arrow on the shaft to which the inner ring of the freewheel is to be mounted.

Ensure that the freewheeling direction of the freewheel matches the direction marked on the shaft.

<b>RINGSPANN</b>	<b>Installation and Operating Instructions for Complete Freewheels FGR, FGR A1A2, FGR A2A7, FGR A2A3, FGR A3A4</b>		<b>E 08.710 e</b>	
	Stand: 23.12.2010	Version : 03	gez.: Su	gepr.: Ei
			Seitenzahl: 10	Seite: 7



**Attention!**

When a freewheel is used as a backstop, the drive must not be started in the direction opposite the freewheeling direction of the freewheel, as otherwise the freewheel may be destroyed!

Are basic freewheel, flange, covers, seals and screws supplied loose, the components are mounted to the customer according to the required direction to a complete freewheel. Before putting the freewheel must point 9 is to be filled with oil.

Apply only uniformly distributed pressure to the front face of the inner ring when mounting the freewheel to the shaft.

If the freewheel is mounted with its outer ring to the centring device supplied by the customer, this operation must be performed by applying uniform pressure to the front face of the outer ring around the entire circumference.



**Attention!**

The freewheel should on no account be heated during assembly, or may not be driven onto the shaft by applying hammer blows. Both can cause damage. The functionality of the freewheel is no longer guaranteed

**9. Inspection prior to commissioning**

The oil level must be checked prior to initial operation of the freewheel. For this purpose, the cover has two oil bores, angularly offset by 120°.

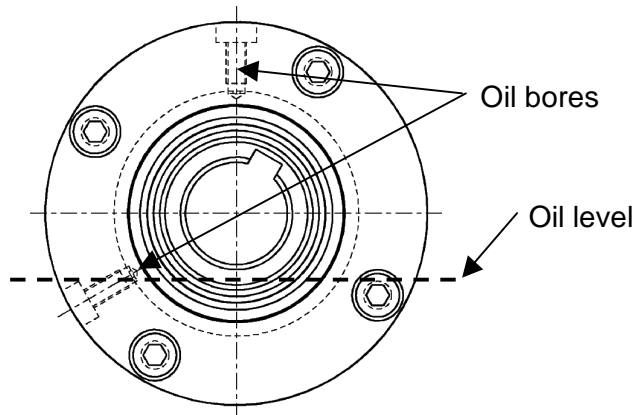

Fig. [2]

- Turn the freewheel until that an oil bore is vertical (see Fig. [2])
- Remove the screws from these two oil bores and take out the gaskets

<b>RINGSPANN</b>	<b>Installation and Operating Instructions for Complete Freewheels FGR, FGR A1A2, FGR A2A7, FGR A2A3, FGR A3A4</b>			<b>E 08.710 e</b>	
	Stand: 23.12.2010	Version : 03	gez.: Su	gepr.: Ei	Seitenzahl: 10

- Pour oil into the vertical oil bore until its runs out of the opposite oil bore. See the oil selection table in Section 11 "Lubricants" for the appropriate grade of oil.
- Close the two oil bores with the gaskets and screws.
- Turn the freewheel-outer ring against to the freewheel-inner ring by hand in the freewheeling direction (freewheeling operation). If the freewheel turns roughly, apply a light hammer blow to the outer ring while turning the freewheel by hand in the freewheeling direction



**Attention!**

A certain degree of friction is caused by the seals. This is reduced after a short time.

**10. Maintenance**



**Attention!**

The first oil change must be performed after 20 hours of operation!

During the first oil change, all particles accumulated during the "running in" procedure should be removed from the freewheel. That is why this oil change is required to ensure the service life of the freewheel.

Subsequent oil changes must be performed after every 2,000 operating hours, at a minimum

When speed differences between the inner ring and outer ring of less than  $100 \text{ min}^{-1}$  longer oil change intervals are allowed after consultation.



<b>RINGSPANN</b>	<b>Installation and Operating Instructions for Complete Freewheels FGR, FGR A1A2, FGR A2A7, FGR A2A3, FGR A3A4</b>			<b>E 08.710 e</b>	
	Stand: 23.12.2010	Version : 03	gez.: Su	gepr.: Ei	Seitenzahl: 10

Oil change procedure:

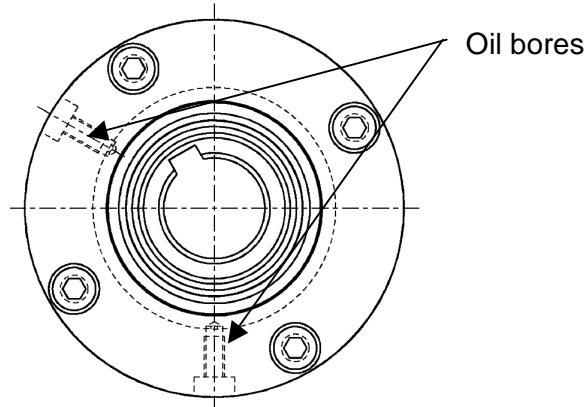

Fig. [3]

- Turn the freewheel so that an oil hole in the cover A2 (or A4) points vertically downwards (see Fig. [3]).
- Remove the two screws and oil seals from the cover A2 (or A4).
- Collect and dispose of the old oil in accordance with applicable regulations.
- Clean the freewheel with cleaning oil and dispose of the cleaning oil in accordance with applicable regulations.
- Turn the freewheel so that an oil bore stands vertically upwards (see Fig. [2]).
- Fill oil into the vertical oil bore until it runs out of the opposite oil bore. See the oil selection table in Section 11 "Lubricants" for the appropriate grade of oil.
- Close the two oil bores with the gaskets and screws.



**Attention!**

If seal problems occur (leakage) during operation, the machine or system must be shut down immediately. Determine the cause of the leak and replace the freewheel if necessary!

<b>RINGSPANN</b>	<b>Installation and Operating Instructions for Complete Freewheels FGR, FGR A1A2, FGR A2A7, FGR A2A3, FGR A3A4</b>			<b>E 08.710 e</b>	
	Stand: 23.12.2010	Version : 03	gez.: Su	gepr.: Ei	Seitenzahl: 10

## 11. Lubricants

Please follow the instructions in Section 9 before commissioning. We recommend the following grades of oil for lubrication or oil changes:

<b>Oil selection table</b>			
<b>Ambient temperature</b>	<b>For ambient temperatures from 0° to 50° C</b>	<b>For ambient temperatures from – 15° to + 15° C</b>	<b>For ambient temperatures from – 40° to 0° C</b>
<b>Kinematic Viscosity at 40° C, ISO-VG</b>	<b>46/68 [mm<sup>2</sup>/s]</b>	<b>32 [mm<sup>2</sup>/s]</b>	<b>10 [mm<sup>2</sup>/s]</b>
AGIP	OSO 46/68	OSO 32	OSO 10
ARAL	VITAM GF 46/68	VITAM GF 32	VITAM GF 10
BP	ENERGOL HLP 46/68	ENERGOL HLP 32	AERO HYDRAULIC 1
CASTROL	VARIO HDX	VARIO HDX	ALPHASYNTH 15
CHEVRON	EP HYDRAULIC OIL 46/68	EP HYDRAULIC OIL 32	HYJET IV
DEA	ASTRON HLP 46	ASTRON HLP 32	ASTRON HLP 10
ELF	ELFOLNA 46	ELFOLNA 32	ELF AVIATION HYDRAULIC OIL 20
ESSO	NUTO H 46/68	NUTO H 32	UNIVIS J 13
KLÜBER	LAMORA HLP 46/68	LAMORA HLP 32	Klüberoil 4 UH1-15
MOBIL	D.T.E. 25/26	D.T.E. 24	AERO HF A
SHELL	TELLUS OIL 46/68	TELLUS OIL 32	TELLUS OIL 10
Other manufacturers	Gearbox or hydraulic oils without solid lubricants ISO-VG 46/68	Gearbox or hydraulic oils without solid lubricants ISO-VG 32;  Automatic transmission fluids [ATF]	Gearbox or hydraulic oils without solid lubricants ISO-VG 10; Note setting point!  Aviation hydraulic oils ISO-VG 10

Please contact us if temperatures exceed + 50 °C or fall below – 40 °C.



### Caution!

Oils that contain friction-reducing additives like molybdenum disulfide or the like, may only be used with our authorisation.